

## Computer Specifications

### CPU and Memory

32-bit CPU      4SX/25: Intel® **i486SX**, 25 MHz microprocessor in PGA-type CPU socket; can be upgraded with optional 487SX/25 or ODP486-25 OverDrive processor

4DX2/50: Intel **i486DX2**, 50 MHz microprocessor in PGA-type CPU socket

System speed      Fast and slow speeds available; fast speed depends on CPU (25 MHz or 50 MHz), slow is simulated 8 MHz speed; speed selection through keyboard command; 0 wait state memory access at fast speed

To select slow speed, press the Ctrl, Alt, and - keys simultaneously. To select fast speed, press the **Ctrl**, Alt, and + keys simultaneously. (Use the - or + key on the numeric keypad.) Default system speed is also user-selectable through SETUP

**Memory**      4MB RAM standard; expandable using 1MB, 4MB, or 16MB SIMMs to 36MB (maximum); SIMMs must be 36-bit, fast-page mode type with 70ns (or faster) access speed

**ROM**      128KB system BIOS, video BIOS, and SETUP code located in EPROM on main system board

**Video RAM**      512KB DRAM on main system board, expandable to 1MB using 256k x 4-bit DRAM ZIPs

**Shadow RAM**      Supports shadowing of system and video BIOS ROM into RAM

**Cache**      8KB of internal cache (built into the microprocessor); expandable to 256KB using 8KB or 32KB, 70ns SRAM DIP chips

**Math coprocessor**      On 4DX2/50 system, math coprocessor built into the microprocessor; optional 487 upgrade available for 4SX/25 system

**Clock/calendar**      Real-time clock, calendar, and CMOS RAM socketed on main system board with built-in battery backup

### Controllers

**Video**      Cirrus® Logic GD5422 VGA controller on main system board; provides true color resolutions up to 800 x 600 with 512KB standard memory; with 1MB upgraded memory, provides resolutions up to 1280 x 1024

**Diskette**      Controller on main system board supports up to two diskette drives or one diskette drive and one tape drive

**Hard disk**      Interface on main system board supports up to two IDE hard disk drives with built-in controllers

### Interfaces

**Monitor**      VGA interface built into main system board for analog or multifrequency VGA monitor; 15-pin, D-shell connector

**Parallel**      One standard 8-bit parallel, uni- or bi-directional interface built into main system board; I/O address selectable through SETUP; 25-pin, D-shell connector

**Serial**      Two RS-232C, programmable, asynchronous interfaces built into main system board; 9-pin, D-shell connectors

Keyboard	PS/2 compatible keyboard interface built into main system board; num lock setting selectable through SETUP; 6-pin, mini DIN connector
Mouse	PS/2 compatible mouse interface built into main system board; 6-pin, mini DIN connector
Option slots	Four 16-bit (or 8-bit) I/O expansion slots, ISA compatible, 8 MHz bus speed; three slots accommodate any size card, bottom slot can hold reduced size card (4.4 inch/110 mm)
Speaker	Internal, piezo-electric speaker on main board
VGA feature connector	IBM compatible VGA pass-through interface built into main system board; 26-pin connector

**Mass Storage**

<b>Diskette drives</b>	Three half-height drives maximum configurable using the following: <b>5.25-inch, 1.2MB</b> (high-density) capacity <b>3.5-inch, 1.44MB</b> (high-density) capacity 5.25inch, 360KB (double-density) capacity <b>3.5-inch, 720KB</b> (double-density) capacity <b>Dual diskette drive: 3.5-inch, 1.44MB and 5.25-inch, 1.2MB</b>
<b>Hard disk drives</b>	<b>3½-inch form factor hard disk drive(s)</b> , up to half-height size; the first mounted vertically, second mounted horizontally
<b>Other devices</b>	Half-height tape drive, CD-ROM, or other storage device; <b>5¼-inch</b> or <b>3½-inch</b> with mounting frames

<b>Keyboard</b>	Detachable, two-position height; 101 or 102 sculpted keys; countrydependent main typewriter keyboard; numeric /cursor control keypad; four-key cursor control keypad; 12 function keys
-----------------	--

<b>SETUP Program</b>	Stored in ROM; accessible by pressing the <b>Delete</b> key at the SETUP prompt during boot
----------------------	---

**Video Modes**

Mods	Resolution	colors
<b>VGA</b>	<b>640 x 480</b>	16
Extended, <b>512KB</b> memory required	<b>640 x 480</b>	1256
	<b>640 x 480</b>	<b>32K</b>
	<b>800X600</b>	16
	<b>800X600</b>	<b>256</b>
Extended, 1 MB memory required	<b>640 x 480</b>	<b>16M</b>
	<b>800 x 600</b>	<b>32K</b>
	<b>800 x 600</b>	<b>64K</b>
	<b>1024 x 768</b>	16
	<b>1024 x 768</b>	<b>256</b>
	<b>1280 x 1024</b>	16

**Power Supply**

<b>Type</b>	<b>85 Watt, fan-cooled</b>
<b>Input ranges</b>	<b>90 to 264 VAC</b>
<b>Maximum outputs</b>	<b>+5 VDC at 11 Amps,</b> <b>+12 VDC at 2.0 Amps,</b> <b>-5 VDC at 0.3 Amps,</b> <b>-12 VDC at 0.3 Amps</b>
<b>Frequency</b>	47 to 63 Hz

*Option Slot Power Limits*

Maximum current	<b>+5 Volts</b>	<b>+12 Volts</b>	<b>-5 Volts and -12 Volts</b>
<b>For each slot</b>	7 Amps	1.5 Amps	0.3 Amps
<b>For all four slots</b>	11 Amps	<b>2 Amps</b>	0.3 Amps

**Environmental Requirements**

Condition	Operating range	Nonoperating range	Storage range
Temperature	<b>41° to 90° F</b> ( <b>5° to 32° C</b> )	<b>-4° to 140° F</b> ( <b>-20° to 60° C</b> )	<b>-4° to 140° F</b> ( <b>-20° to 60° C</b> )
<b>Humidity (non-condensing)</b>	20% to 90%	10% to 90%	10% to 90%
Attitude	-330 to 9,900 ft (-100 to 3,999 m)	-330 to 39,699 ft (-100 to 12,000 m)	330 to 39,600 ft (-100 to 12,990 m)
Maximum wet bulb	<b>68° F</b> ( <b>20° C</b> )	<b>104° F</b> ( <b>40° C</b> )	<b>134° F</b> ( <b>57° C</b> )
Acoustical noise	37.5 dB(A)	N/A	N/A

**Physical Characteristics**

<b>Width</b>	14.8 inches (370 mm)
<b>Depth</b>	16.5 inches (412 mm)
<b>Height</b>	4.8 inches (120 mm)
<b>Weight</b>	16.7 b (7.5 kg), with one diskette drive and one hard disk, but without keyboard

# Main System Board Diagram

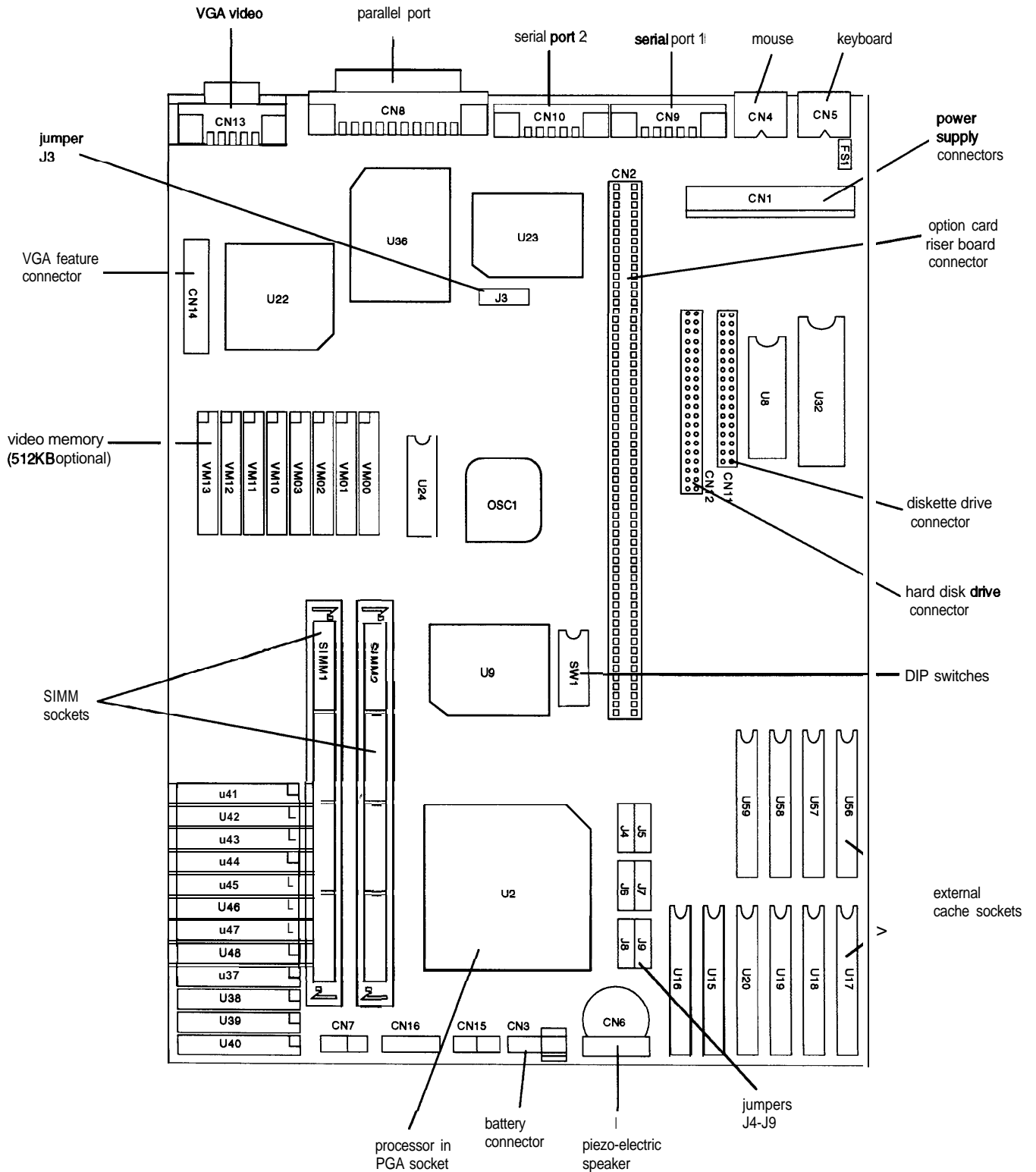

## Major Subassemblies

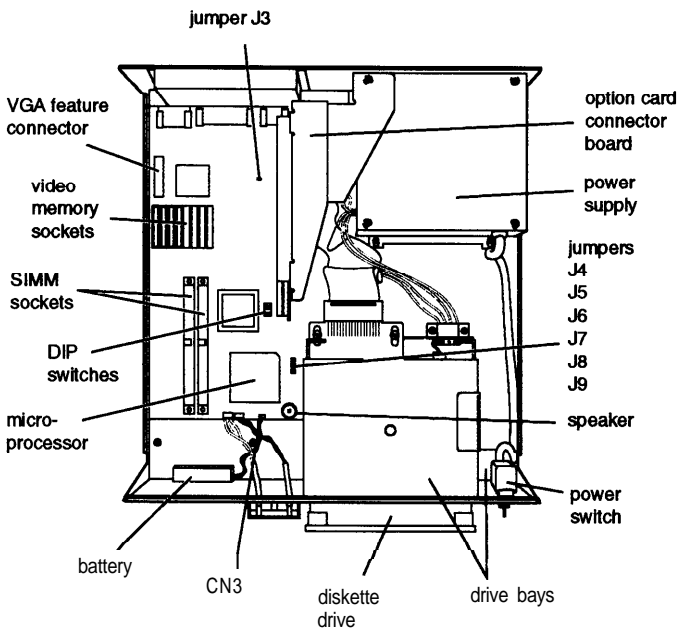

## Connector Pin Assignments

### Parallel Port Connector (CN8)

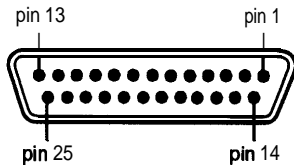

#### Parallel Port Connector Pin Assignments

Pin	Signal	Pin	Signal	Pin	Signal
1	Strobe	10	ACK'	19	Signal ground
2	Data 0	11	Busy	20	Signal ground
3	Data 1	12	PE	21	Signal ground
4	Data 2	13	Select	22	Signal ground
5	Data 3	14	Auto'	23	Signal ground
6	Data 4	15	Error*	24	Signal ground
7	Data 5	16	Init	25	Signal ground
8	Data 6	17	Selectin*		
9	Data 7	18	Signal ground		

\*Active low logic

### Serial Port Connectors (CN9 and CN10)

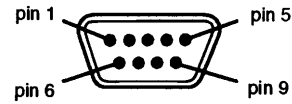

#### Serial Port Connector Pin Assignments

Pin	Signal	Pin	Signal
1	Data carrier detect	6	Data set ready
2	Receive data	7	Request to send
3	Transmit data	8	Clear to send
4	Data terminal ready	9	Ring indicator
5	Not used		

### Keyboard Connector (CN5) and Mouse Connector (CN4)

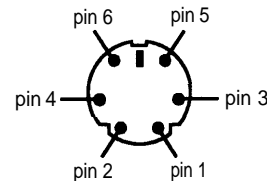

Although the keyboard and mouse connectors are physically identical, they cannot be used interchangeably.

#### Keyboard and Mouse Connector Pin Assignments

Pin	Signal	Pin	Signal
1	Data	4	+5VDC (fused)
2	Resewed	5	Clock
3	Ground	6	Reserved

### VGA Port Connector (CN13)

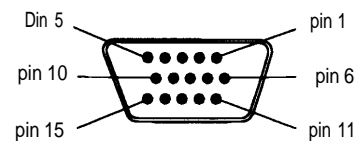

#### VGA Port Connector Pin Assignments

Pin	Signal	Pin	Signal	Pin	Signal
1	Red	6	Red ground	11	NC
2	Green	7	Green ground	12	NC
3	Blue	8	Blue ground	13	Horizontal sync
4	NC	9	NC	14	Vertical sync
5	Ground	10	Ground	15	NC

### VGA Feature Connector (CN14)

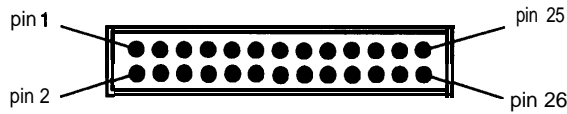

#### VGA Feature Connector Pin Assignments

Pin	Signal	Pin	Signal	Pin	Signal
1	Data 0	10	BLANK	19	ENPCLK*
2	Data 1	11	HSYNC	20	Not connected
3	Data 2	12	VSYNC	21	Ground
4	Data 3	13	Ground	22	Ground
5	Data 4	14	Ground	23	Ground
6	Data 5	15	Ground	24	Ground
7	Data 6	16	Ground	25	Not connected
8	Data 7	17	ENDATA*	26	Not connected
9	PCLK	18	ENSYNC*		

\*Active low logic

### DMA Assignments

Level	Assigned device
DMA0	Spare (8-bit)
DMA1	Spare (8-bit)
DMA2	Diskette drive controller (8-bit)
DMA3	Spare (8-bit)
DMA4	Cascade for DMA controller
DMA5	Spare (16-bit)
DMA6	Spare (16-bit)
DMA7	Spare (16-bit)

### Hardware Interrupts

IRQ no.	Function
IRQ0	Timer output
IRQ1	Keyboard
IRQ3	Serial port 2
IRQ4	Serial port 1
IRQ5	Available (parallel port 2)
IRQ6	FDD controller
IRQ7	Parallel port 1
IRQ8	Real-time clock
IRQ9	Available
IRQ10	Available
IRQ11	Available
IRQ12	PS/2 compatible mouse, optional pointing devices
IRQ13	Math coprocessor
IRQ14	HDD controller
IRQ15	Available

### System I/O Address Map

Hex address *	Assigned device
000 - 01F	DMA controller 1, 8237A-5
020 - 03F	Interrupt controller 1, 8259A, master
040 - 05F	Timer, 8254-2
060 - 06F	8042 (Keyboard and mouse)
070 - 07F (CMOS)	Real-time clock (non-maskable interrupt mask)
080 - 09F	DMA page register, 74LS612
0A0 - 0BF	Interrupt controller 2, 8259A
0C0 - 0DF	DMA controller 2, 8237A-5
0F0	Clear math coprocessor busy
0F1	Reset math coprocessor
0F8 - 0FF	Math coprocessor
1F0 - 1F8	Hard disk
200 - 207	Game I/O
278 - 27F	Parallel printer port 2
2B0 - 2DF	Alternate enhanced graphics adapter
2E1	GPIB (adapter 0)
2E2 and 2E3	Data acquisition (adapter 0)
2F8 - 2FF	Serial port 2
300 - 31F	Prototype card
360 - 363	PC network (low address)
368 - 36B	PC network (high address)
378 - 37F	Parallel printer port 1
380 - 38F	SDLC, bisynchronous 2
390 - 393	Cluster
3A0 - 3AF	Bisynchronous 1
3B0 - 3BF	Monochrome display and printer adapter
3C0 - 3CF	Enhanced graphics adapter
3D0 - 3DF	Color/graphics monitor adapter
3F0 - 3F7	Diskette drive controller
3F8 - 3FF	Serial port 1
6E2 and 6E3	Data acquisition (adapter 1)
790 - 793	Cluster (adapter 1)
AE2 and AE3	Data acquisition (adapter 2)
B90 - B93	Cluster (adapter 2)
EE2 - EE3	Data acquisition (adapter 3)
1390 - 1393	Cluster (adapter 3)
22E1	GPIB (adapter 1)
2390 - 2393	Cluster (adapter 4)
42E1	GPIB (adapter 2)
62E1	GPIB (adapter 3)
82E1	GPIB (adapter 4)
A2E1	GPIB (adapter 5)
C2E1	GPIB (adapter 6)
E2E1	GPIB (adapter 7)

\* I/O addresses hex 000 to 0FF are reserved for the system board I/O. Hex 100 to 3FF are available on the system channel.

## System Memory Map

23FFFFF	Extended memory	36MB
0100000		
	System BIOS (Shadow RAM, 64KB)	1MB
00F0000	Reserved for system BIOS (64KB)	
00E0000	Reserved for ROM on I/O cards	
00C7FFF	VGA BIOS ROM (Shadow, 32KB)	
00c0000	VGA Color Text	
00B8000	VGA Mono Text	
00B0000	VGA Graphics	
00A0000	Base memory	640KB
0000000		

## Jumper and DIP Switch Settings

### Display Adapter and CPU Jumper Settings

Jumper	Setting	Function
J3	A B	Enable the built-in VGA adapter Disable the built-in VGA adapter so you can use a display adapter on an option card as your primary adapter
J4	A** B	Select DX2 CPU select SX CPU

\* Factory setting    \*\* Factory set according to system CPU

### External Cache Jumper Settings

Cache Size	J5	J6	J7	J8	J9
OKB*	B	B	B	B	A
32KB	A	A	A	A	A
64KB	A	B	A	B	A
128KB	B	B	A	A	A
256KB	B	B	B	B	B

\* Factory setting; change jumpers only if external cache chips are installed

### Hard Disk Drive Jumper Settings

Model Number	Single Drive	Master Drive	Slave Drive
Conner CP30104H	C/D jumpered	C/D and DSP jumpered	no jumpers
Conner CP30174E	C/D jumpered	C/D jumpered	no jumpers
Quantum LPS240AT	DS jumpered*	DS jumpered*	no jumpers'

\* If CS (cable selection) is jumpered, the drive is a master if pin-28 is grounded and a slave if pin-28 is not grounded.

### DIP Switch Settings

Switch	Setting	Function
1**	ON	33 MHz CPU speed
	OFF	25 MHz CPU speed
2**	ON	25 MHz CPU speed
	OFF	33 MHz CPU speed
3**	ON	CPU present in PGA socket
	OFF	CPU absent from PGA socket
4	ON	Enable password security feature
	Off	Disable password security feature
5	ON	Select color monitor
	OFF	Select monochrome monitor

\* Factory setting    . \* Factory set according to system type

## Processor Chips

The 4SX/25 system can be upgraded with an Intel OverDrive processor on the main system board to effectively double the internal clock speed of the computer's microprocessor. Alternatively, the 4SX/25 accepts the Intel 487SX/25 microprocessor with built-in math coprocessor.

## SIMM Installation

The computer comes with 4MB of memory on the main system board. To increase the amount of memory in the computer up to 36MB, install 36-bit, fast-page mode SIMMs that operate at an access speed of 70ns or faster, with a capacity of 1MB, 4MB, or 16MB.

The following table shows the possible SIMM configurations; do not install memory in any other configuration.

### SIMM Configurations

SIMM1	SIMM2	Total
0	0	4MB*
1MB	0	5MB**
4MB	0	8MB**
1MB	4MB	9MB**
4MB	4MB	12MB
16MB	0	20MB**
1MB	16MB	21MB**
4MB	16MB	24MB**
16MB	16MB	36MB

\* Standard memory on the system board

\*\* SIMMs can occupy either socket

## Video Memory

If the computer has 512KB of video memory, you can install four 256K x 4 bit, 70ns, 20-pin DRAM ZIP (Zig-zag Inline Package) chips to increase the video memory to 1MB. The following table lists compatible DRAM ZIP chips.

*Supported Video ZIP Chips*

Manufacturer	Part number
Goldstar®	GM71 C4256AZ-70
Micron®	MT4C42562-6, MT4C4256Z-7
Samsung®	KM44C256CZ-6, KM44C256CZ-7

## Cache Memory

Additional cache memory can be installed in eight sockets in Bank 0 and Bank 1 on the main system board. The figure below shows how the SRAM are distributed.

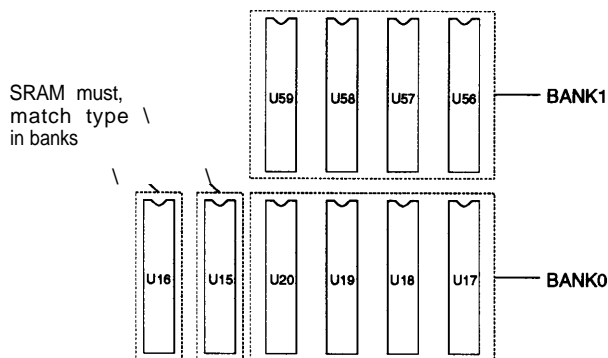

8KB or 32KB SRAM chips can be installed. Bank 0 must be filled before Bank 1. The SRAM type used for dirty RAM and tag RAM must match the type installed in the banks. The table below shows the possible configurations.

*Cache Memory Configuration*

Cache size	Bank 0	Bank 1	Dirty	Tag
0KB	—	—	—	—
32KB	4 x 8KB	0	1 x 8KB	1 x 8KB
64KB	4 x 8KB	4 x 8KB	1 x 8KB	1 x 8KB
128KB	4 x 32KB	0	1 x 32KB	1 x 32KB
256KB	4 x 32KB	4 x 8KB	1 x 32KB	1 x 32KB

## Hard Disk Drive Types

The table below lists types of hard disk drives supported by the computer. Check this table and the hard disk manual to find the correct type number(s) for the hard disk drive(s) installed in the computer. Enter the type number(s) when you set the hard disk drive configuration in the SETUP program.

*Hard Disk Drive Types*

Type no.	Cylinders (CYL)	Heads (HDS)	Precomp	Landing zone	Sectors (SEC)	Size* (in MB)	Drive name/manufacturer
1	306	4	128	306	17	10	
2	615	4	300	615	17	20	ST-225, ST-4026, WD-93024
3	615	6	300	615	17	31	ST-138A †
4	940	8	512	940	17	62	
5	940	6	512	940	17	47	
6	615	4	65535	615	17	20	CP-3024, ST-125, ST-125A, ST-325A
7	462	8	256	511	17	31	
8	733	5	65535	733	17	30	ST-4038
9	900	15	65535	901	17	112	
10	820	3	65535	820	17	20	
11	855	5	65535	855	17	35	
12	855	7	65535	855	17	50	
13	306	8	128	319	17	20	
14	733	7	65535	733	17	42	
15							-reserved-
16	612	4	0	663	17	20	
17	977	5	300	977	17	41	CDC 94205-51, CP-3044 †, CP-2044 †, 7040 †, 8051A †
18	977	7	65535	977	17	57	
19	1024	7	512	1023	17	60	CP-2064
20	733	5	300	732	17	30	MK-133FA
21	733	7	300	732	17	43	MK-134FA, ST-157A †
22	733	5	300	733	17	30	
23	306	4	0	336	17	10	
24	903	4	65535	902	46	81	CP-30084 ‡
25	776	8	65535	775	33	100	CP-3104
26	903	8	65535	902	46	162	
27	698	7	300	732	17	41	
28	976	5	788	977	17	79	
29							-reserved-
30							-reserved-
31	732	7	300	732	17	43	
32	1023	5	65535	1023	17	42	
33	901	5	65535	900	53	117	LPS120AT ‡
34	723	13	65535	722	51	234	LPS240AT ‡
35	934	16	65535	933	17	124	MK2124FC
36							-reserved-
37	683	16	65535	682	38	203	CP-3204F
38	548	8	65535	547	38	81	CP-2084
39	761	8	65535	760	39	116	CP-30104
40	980	10	65535	979	17	81	7080A, MK2024FC
41	1022	5	65535	1022	34	85	CDC 94216-106 (ESDI)
42	1022	5	65535	1022	36	90	CDC 94216-106
43	1024	8	512	1023	17	68	1325, 3085, LAN64, XT1085, NDR1085
44	828	10	65535	828	34	137	MK-156F
45	1024	5	512	1023	17	43	
46	615	8	128	618	17	40	
47							-user defined-

\* Actual size when formatted may be slightly different than the size listed on the drive label

† Hard disk drive supported in translate mode

‡ Epson drives

## **Installation / Support Tips**

---

### **Mouse and Keyboard**

- ❑ When connecting the mouse and keyboard to the computer, be careful to plug them into the proper ports. Although the ports are physically identical, they are not interchangeable, and damage may occur to the main system board if you plug the connectors into the wrong ports.

### **Installing Diskette Drives**

- ❑ Make sure that the drive type has been correctly selected in the SETUP program.

### **Installing Hard Disk Drives**

- ❑ It is recommended that a 16-bit, AT-type hard disk controller be used if you are installing a drive that cannot use the embedded IDE interface. If you install a non-IDE hard disk drive and controller card, you need to use the SETUP program to disable the built-in IDE hard disk drive interface.
- ❑ When installing a hard disk drive, see the hard disk drive types table on page 7 and use the SETUP program to select the correct type number for the drive. You can select a type number that matches the parameters for the drive or a type number with parameters having lesser values, as long as they do not exceed the maximum capacity (in MB) of the drive. If there is no match for the drive, you can select a user-defined drive type (47) and enter the drive's exact parameters.

### **Software Problems**

- ❑ When installing a copy-protected software package, first try the installation at fast speed. If this does not work properly, select slow speed by pressing the Ctrl and Alt keys and the - key on the numeric keypad simultaneously. Try loading the program at slow speed and then switching to fast speed, if possible.
- ❑ When using a software package that uses a key disk as its copy-protection method, try loading it at fast speed. If this does not work, load it at slow speed.

### **Password**

- ❑ Make sure that you do not forget the password you set up. If you do:
  1. Disable it by setting DIP switch 4 on the main system board to OFF.
  2. Then turn the computer on and off again.
  3. Set DIP switch 4 to ON to enable the password function.
  4. Run SETUP to enter a new password, if desired.
- ❑ Users can enter a hot key designation in SETUP to secure the system from unauthorized users. Once a password and hot key have been set, when the hot key is pressed, the keyboard and mouse lock until the user enters the password.

### **Booting Sequence**

- ❑ If you cannot boot the computer from the hard disk drive, make sure the booting sequence in the SETUP program is set to A, C. Then boot the computer from a system diskette in drive A.

---

## **Information Reference List**

---

### **Engineering Change Notices**

None.

### **Technical Information Bulletins**

None.

### **Product Support Bulletins**

None.

### **Related Documentation**

TM-EQ4+	Epson Equity 4+ Service Manual
PL-EQ4+	Epson Equity 4+ Parts Price List
400264700	Epson Equity 4+ User's Guide